

Special installation instructions for Raymarine SmartPilot X-10 Corepack

The SmartPilot X-10 Corepack autopilot can be used in combination with the Jefa Direct Drive type 1 and the 12 volt transmission and sprocket drives. There is an issue on the clutch control: The maximum allowed clutch power is 1,2 Amps and the required power is 1,4 Amps. To overcome this, a car contactor (relais) between the clutch ports and the clutch of the drive unit has to be installed. This contactor has to be ordered separately with the code number DU-RE-12.

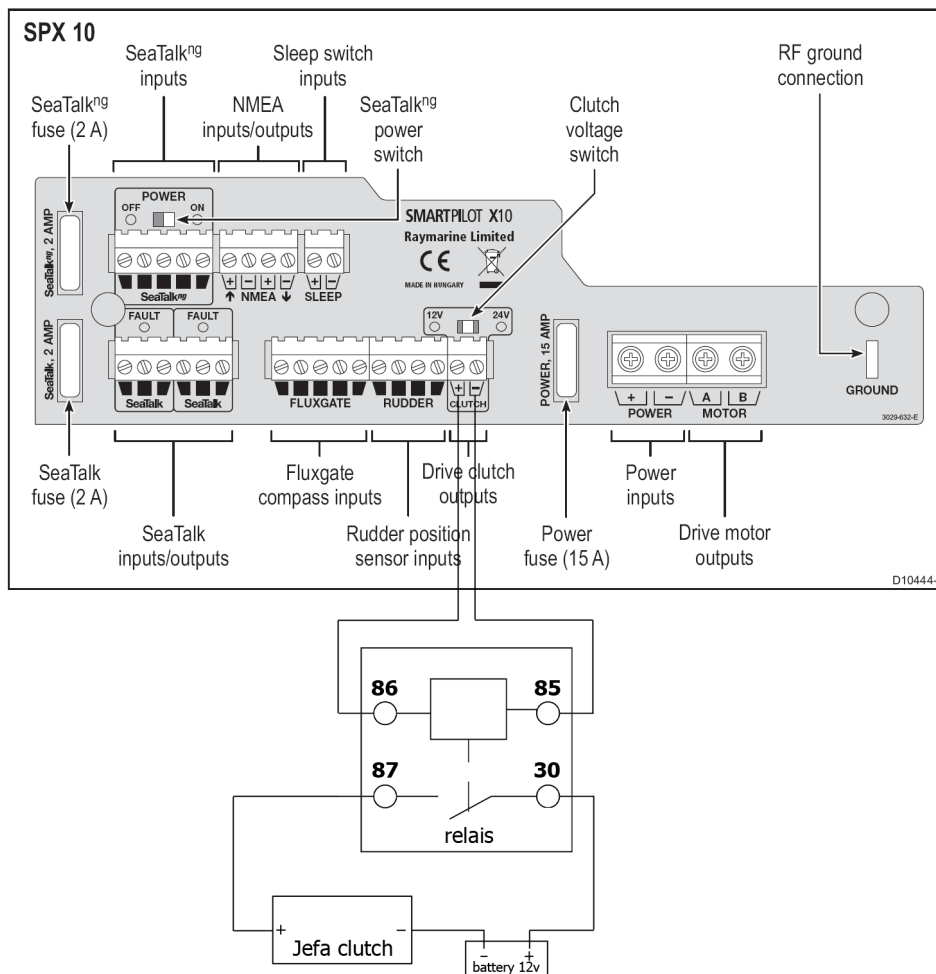

We strongly advise to not use the standard X10 autopilot as standard delivered without rudder feedback unit. Without rudder feedback unit the autopilot is not aware of actual rudder angle. In very slow speed conditions or in conditions of a stalling rudder blade, the autopilot doesn't stop with powering the drive unit, running it against the rudder stops and still continuing to power the drive. In time the drive fuse will blow, but mechanical damage can occur in the drive unit which will not be covered under our warranty terms as we can identify this specific damage. We strongly advise only to use the X10 unit in combination with the optional rudder feedback unit or use the X30 unit.



Please make sure the clutch voltage is switched to 12 Volts.

Jefa Steering ApS
 Agenavej 43
 2670 Greve
 Denmark
 Tel: +45 46 155210
 Fax: +45 43 695211



www.jefa.com

15.06.2009