

Test data:

Customer:

Test Engineer:

Date:

Serial number:

Output torque 200 Nm:

motor type DU-TS24-12 – 8 revolutions/minute

Motor Voltage: 12 Volts

motor type DU-TS18-12 – 6 revolutions/minute

Clutch voltage: 12 Volts

motor type DU-TS10-12 – 3.5 revolutions/minute

Insulation test:

Electrical Connections:

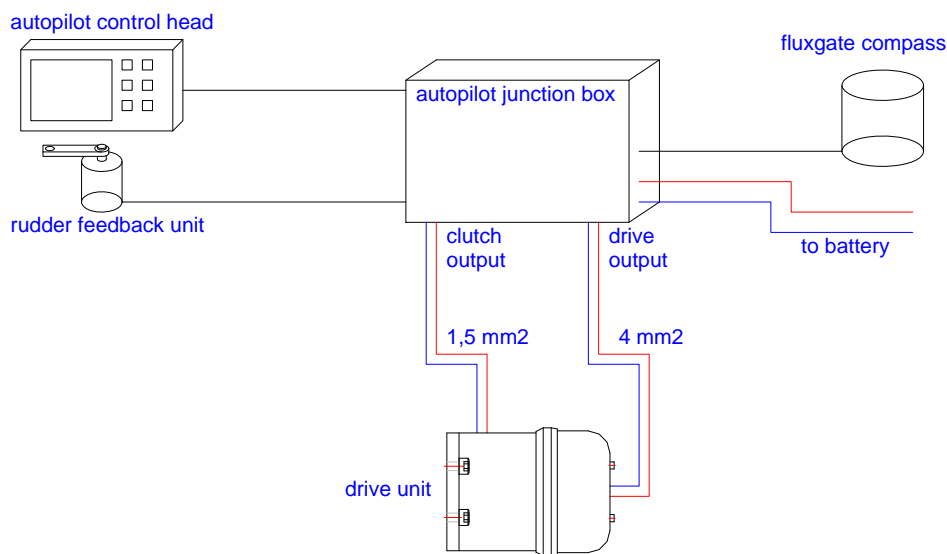

This illustration shows the minimal components for a working autopilot configuration. Jefa autopilot drives work together with all major autopilot electronics. The connection of the Jefa autopilot drive to the autopilot junction box is quite simple. The two 1.5 mm² red and black wires have to be connected to the plus and minus of the autopilot clutch line. This will make sure that when the autopilot user engages the autopilot on the control screen, the clutch will engage and allow the autopilot motor to drive the

steering system. The two 4 mm² red and black wires have to be connected to the autopilot drive output connection.

DD2-12 volts performance table:

rudder torque full rudder (KgM)	rudder torque midships (KgM)	power usage (amps)	rudder rotation per second (degrees/sec.)	time for 72° rudder (sec)
0 (no load)	0	0.5	6.7	11
120	60	6	4.9	15
180	90	9	4.4	17
300	150	15	3.2	23
360	180	18	2.6	28
480	240	24	1.3	55

Compatibility in 12 Volts:

Following table shows the maximum rudder torques at midships and full rudder that can be generated by the Jefa direct drive in combination with various autopilot junction boxes and reduction gearboxes. As the transmission drive drives the steering system, the maximum rudder torque depends on the type of reduction box used in the system. The hard over time (HO-time) states the time it takes the drive to travel the full 72 degrees of rudder travel when the speed control of the pilot is set to maximum speed.

Autopilot junction box 12 Volt version.	Max. output (Amp.)	DD2 torque midships (KgM)	DD2 torque full rudder (KgM)
DU-TS24-12	8 revs/min	11 sec.	
DU-TS18-12	6 revs/min	14 sec.	
DU-TS10-12	3.5 r./min	24 sec.	
Simrad AC12	12	123	233
Simrad AC20	20	169	321
Simrad AC40	40	fully functional, but smaller autopilot is advisable (money can be saved by choosing smaller autopilot)	
B&G h1000 (*1)	25	169	321
B&G h2000 ACP-1	25	169	321
B&G h2000 ACP-2	40	fully functional, but smaller autopilot is advisable (money can be saved by choosing smaller autopilot)	
Nexus-Silva A-1510 (*2)	15	158	299
NKE gyropilot 2 RVP (*3)	25	169	321
Navman G-Pilot (*4)	20	169	321
Northstar MCU600 (*4)	20	169	321
Furuno Navpilot 500/511/520	25	169	321
Raymarine X-10 (*5)(*6)	10	123	233
Raymarine X-30	30	169	321

(*1) Please use part number h1000-CUW specially made for Jefa drives, equipped with dynamic braking. Don't use the standard h1000.

(*2) Please read the special installation instructions for the clutch available on our FTP server via [this direct link](#).

(*3) Please read the special installation instructions for the clutch available on our FTP server via [this direct link](#).

(*4) Please read the special installation instructions for the clutch available on our FTP server via [this direct link](#).

(*5) Please read the special installation instructions for the clutch available on our FTP server via [this direct link](#).

(*6) We strongly advise to not use the standard X10 autopilot as it delivered without rudder feedback unit. Without rudder feedback unit the autopilot is not aware of actual rudder angle. In very slow speed conditions or in conditions of a stalling rudder blade, the autopilot doesn't stop with powering the drive unit, running it against the rudder stops and still continuing to power the drive. In time the drive fuse will blow, but mechanical damage can occur in the drive unit which will not be covered under our warranty terms as we can identify this specific damage. We strongly advise only to use the X10 unit in combination with the optional rudder feedback unit or use the X30 unit.

Fuse Protection:

To protect the autopilot drive, the rudder, and the steering system, your Jefa transmission drive is fitted with an inline fuse. Please don't remove this fuse as this will invalid your warranty. The 12 volt transmission drive is fitted with a 20 Amps fuse. A spare fuse is also supplied in the installation manual bag.



Mechanical installation:

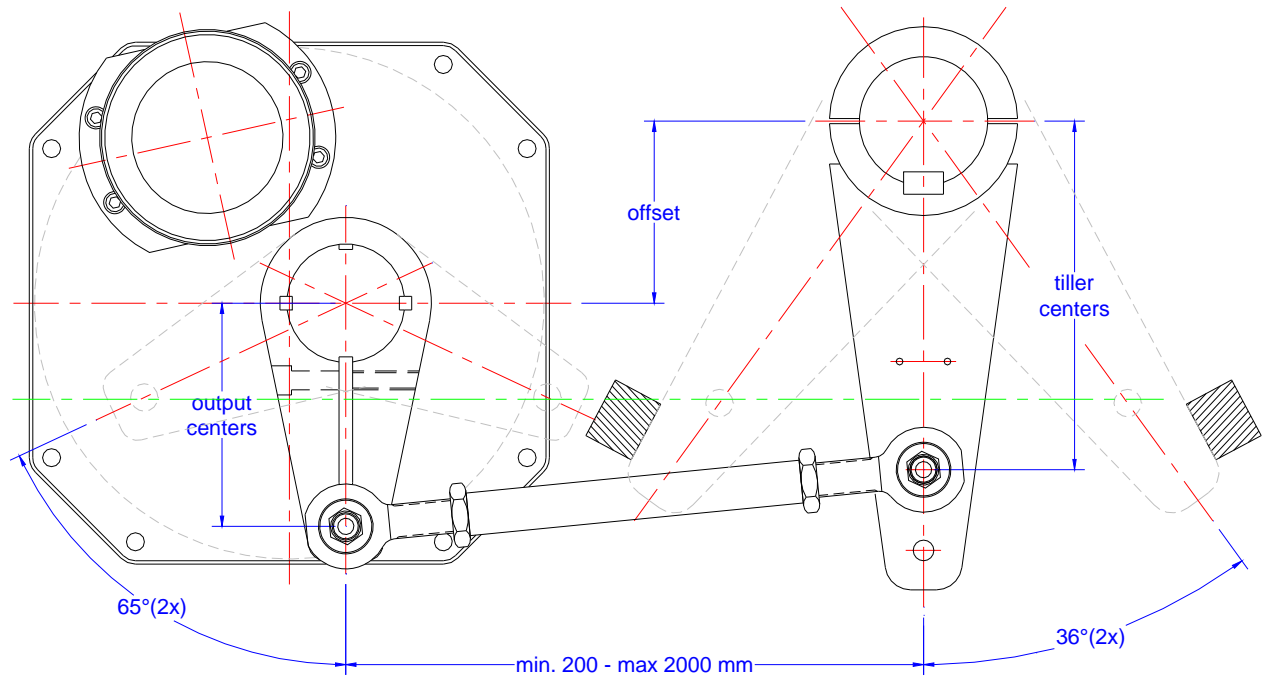

The direct drive uses “wide angle geometry”. The result of this is 128° travel of the output lever and 72° travel of the tiller lever. To achieve an equal travel of the drive in port and starboard, the centre point of the output lever needs an offset to the rudderstock centre. The offset depends on the used lever centres. Following table shows the correct offset distances:

Operating centres in mm valid for 72° (2x36°) rudder travel.		
Output centre	Offset distance	Tiller centre
130	106	200
165	127	250
200	162	307

A good installation check is to make sure all end-position points are in one line (see green line in illustration).

Test the system:

Before you can test the system, make sure following things are correct:

- Solid rudder stops should be fitted limiting the rudder travel to an equal travel of 36 degrees from midships to port and starboard.
- Make sure all bolted parts (tiller pins, rosejoints, draglinks, tillerarm, etc) are firmly tightened and will not come loose even when exposed to heavy vibrations. Use locktite when necessary.
- Move the complete system from port to starboard making sure the rosejoints don't hit the output lever and tiller lever.
- Make sure the drive output lever rotates equally around 65 degrees to both sides and there is no risk for the output lever to go “over dead centre” so it can't return to the initial position any more, blocking the system.

Connect the electronics. Make absolutely sure the autopilot is set to “reversible drive” or equivalent. Don't use settings like “solenoid” or “hydraulic drive” as these settings will disable the speed control of the autopilot leaving the drive running at 100% speed or 0%, but nothing in between. Make sure the clutch voltage is set to the correct voltage. Some brands have a default clutch voltage that has to be changed. B&G uses 9 volts as standard, Raymarine uses 12 volts, both even on 24 volts input. This should be adjusted to the correct voltage to guarantee a proper working of the clutch. The B&G and Raymarine course computer has to be opened for dip switches to be changed. The Simrad pilot can be adjusted via software in the setup menu on the screen. Always fit the delivered fuse into the power feed line. Failing to install this fuse could mechanically overload the drive causing severe damage inside the drive unit.

When the drive doesn't react to the electronics, test the drive by bypassing it: Connect a plus and minus wire to the battery or fuse box and first connect the clutch, one should here a click when connecting and disconnecting. With the clutch under power, connect power for a short time to the motor cables. The system should get in motion now. Don't connect the cables too long as the drive will try to continue, even when the rudder stops are reached, with potential damage to the structure. If motion is detected, one can rule out the drive causing the malfunction.

Maintenance:

The direct drive is “greased for life”, so should no be opened. No maintenance is required except for periodic checks of all bolted connections. As the rudder system, the steering system and the autopilot drive is exposed to heavy vibrations (mainly by cruising on motor), all bolted connections should be yearly checked. The only parts that could wear in time are the balls of the draglink. These balls are easy exchangeable and available for around 10 € each from any Jefa distributor.

Declaration of conformity:

I, Stig Jensen of Jefa Marine Steering ApS, Nimbusvej 2, 2670 Greve, Denmark, confirm that the Jefa direct drive type II, when fitted in accordance with these installation instructions, will meet the requirements of the Electro Magnetic Compatibility Directive Standard contained within Standard No. 60945/A1.

Signed:.....
Stig Jensen

Date: 06-10-2003

For more information please visit our website www.jefa.com

Special installation instructions for low power clutch lines

The Jefa direct drive unit can operate with a relatively small course computer. This is due to the high efficiency of the drive unit. The direct drive unit requires a current of 1,4 Amps to contract the clutch and to keep it contracted. Many small course computers can't deliver this power. To overcome this, a car contactor (relais) between the clutch ports and the clutch of the drive unit has to be installed. This contactor has to be ordered separately with the code number DU-RE-12 or could be purchased in a local car shop.

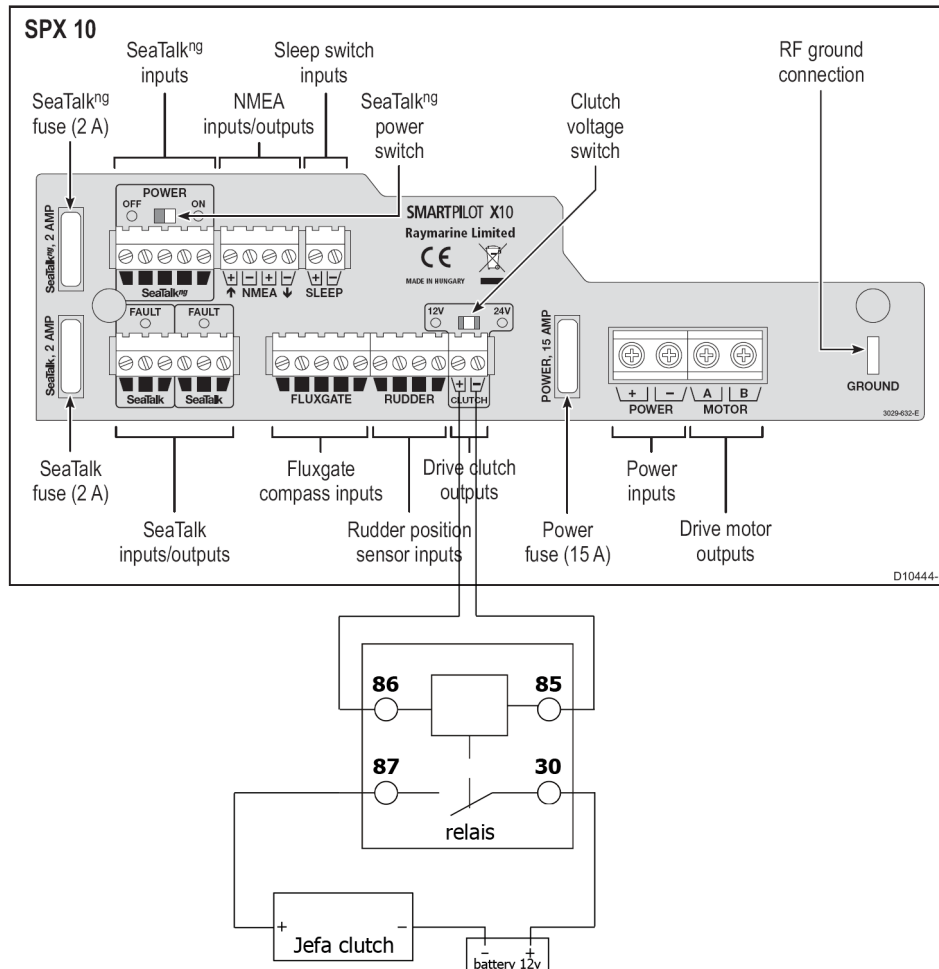

Example of the wiring diagram for the contactor.

Jefa Steering ApS
 Agenavej 43
 2670 Greve
 Denmark
 Tel: +45 46 155210
 Fax: +45 43 695211



www.jefa.com

03.09.2009